

## BABG-20 Countertop Mixer

20-quart capacity

Item#21698

### STANDARD FEATURES

- 3 speed direct drive gear transmission
- Safety cut-switch automatically turns the unit off if gears are changed without stopping the mixer
- #12 hub
- Digital control
- Surface protection feet covers
- Comes standard with:
  - Dough hook
  - Wire whip
  - Flat beater
  - Stainless steel mixing bowl
  - Safety guard
- Extra bowls available (Item # 21698-2)



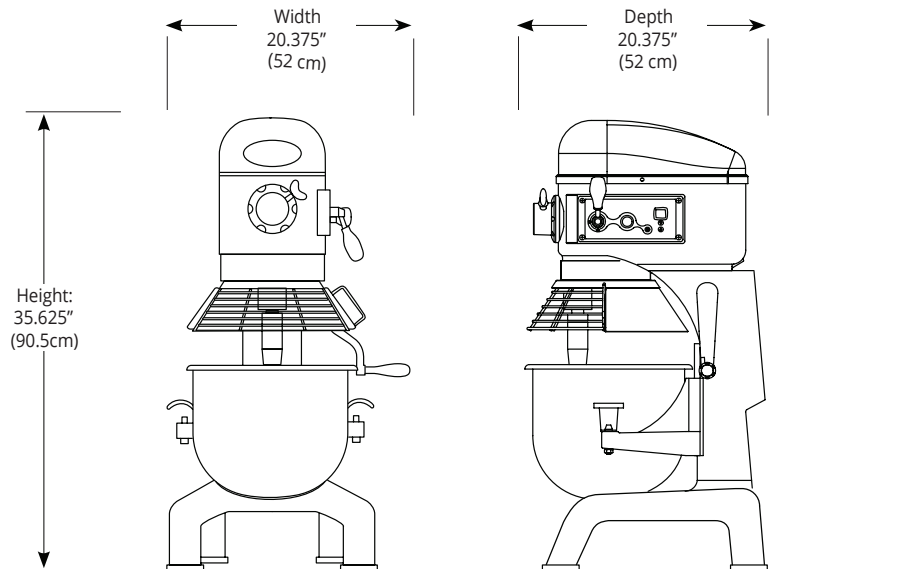

#### CONTROL PANEL

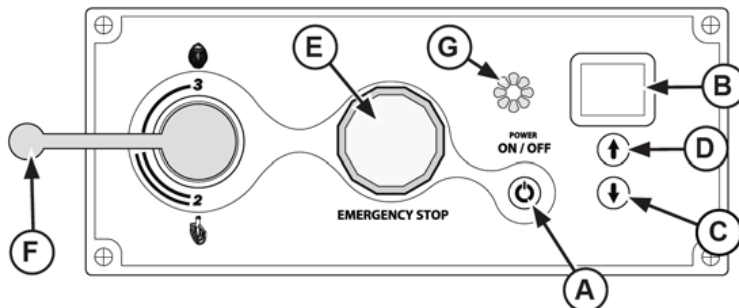

**(A) ON/OFF BUTTON**

**(B) DIGITAL DISPLAY**

- Displays time remaining when in timed operation cycle
- Displays "ON" when operating in a non-timed mode
- Displays "OFF" when not operating

**(C) TIME UP BUTTON**

- Increases the time. Maximum time of 30 minutes

**(D) TIME DOWN BUTTON**

- Decreases the time

**(E) STOP BUTTON**

**(F) SPEED SELECT LEVER**

**(G) INDICATOR LIGHTS**

- Lights are on when mixer is in operating mode.

#### Dimensions and weight (NET)

- Width: 20.375" (52 cm)
- Depth: 20.375" (52 cm)
- Height: 35.625" (90.5cm)
- Net weight: 209 lbs (45 kg)

#### Shipping Dimensions (GROSS)

- 40"x48"x48" (102x122x122cm)
- Gross Weight: 291 lbs (132 kg)

#### Electrical

- Volts: 120V
- Amps: 10A
- HP: 1/2 hp
- Plug: NEMA 5-15P
- Cord: 6 ft (1.8 m)

#### Certifications

- Certified ETL-C-US, NSF