

Belshaw[®]

Cake Donut Cutter Type N



Operator's Manual Technical Supplement

Belshaw Adamatic Bakery Group
814 44th Street Northwest, Suite 103
Auburn, WA 98001 USA
1-800-BELSHAW • 800-578-2547 • (1) 206 322-5474 •
service@belshaw.com • www.belshaw.com

EQUIPMENT RECORD

Please provide the information below when you correspond with Belshaw about your machine.

Purchased by _____

Installed by _____

Date of Installation _____

Model number _____

Serial number _____

IN CASE OF DAMAGE TO EQUIPMENT

In case of damage to the equipment upon delivery, follow these steps immediately.

1. Inform the freight carrier. The phone number will be on the shipping receipt or label.
2. Take photographs of the equipment, both inside and outside the box or crate.
3. Do not throw away any packaging.
4. Report the damage to the distributor (or other party) from whom you bought the equipment.
5. Email your photos to the distributor (or other party) AND to Belshaw Customer Service at service@belshaw.com. Include a Belshaw Order Number in your communications. Your Order Number will begin with "CO...", followed by 6 digits) and should be marked on the box or crate.

IN CASE OF MISSING ITEMS

1. If possible, note the missing items on the delivery receipt of the freight carrier.
2. Take photographs of the entire shipment.
3. Follow steps 2 – 5 above.

Belshaw Adamatic Bakery Group
814 44th Street Northwest, Suite 103
Auburn, WA 98001 USA
1-800-BELSHAW • 800-578-2547 • (+1) 206 322-5474 •
service@belshaw.com • www.belshaw.com

Contents

OPERATOR'S MANUAL

<u>1</u>	<u><i>Operation</i></u>	<u>5</u>
<u>2</u>	<u><i>Cleaning</i></u>	<u>6</u>
	Care, Maintenance, and Cleaning for Plungers and Hoppers	6
	Care and Cleaning of Cutters and Dispensers	7
<u>3</u>	<u><i>Maintenance</i></u>	<u>8</u>
<u>4</u>	<u><i>Donut Making Helps</i></u>	<u>9</u>
	Calculating Correct Water Temperature	10
	Ratios of Plunger Sizes to Donut Weights	10
	Temperature Conversion	10

TECHNICAL SUPPLEMENT

<u>5</u>	<u><i>Assembling the Cutter</i></u>	<u>16</u>
<u>6</u>	<u><i>Cut-N-Fry Installation with Type N and 616B Fryer</i></u>	<u>17</u>
	Mounting Instructions	17
<u>7</u>	<u><i>Wall-Mount Installation</i></u>	<u>19</u>
	Wall mount installation	19
<u>8</u>	<u><i>Maintenance</i></u>	<u>20</u>
	Operation and Maintenance hints:	20
<u>9</u>	<u><i>Parts List and Diagrams</i></u>	<u>20</u>

Preface

The Type N Variety Cutter is designed to cut cake donut products and deposit them in a variety of smaller fryers. It is designed to be mounted on a wall or on a fryer mount.

During production, the operator must move the Cutter, holding the guide handle, to deposit donuts in the desired locations in the fryer. The operator must work safely at all times and read this manual and follow its instructions and warnings.

A thorough understanding of how to install, maintain, and safely operate the Type N Variety Cutter will prevent production delays and injuries. Heed the following warnings and all other warnings that appear in this manual:

- Make sure the machine is mounted securely. Doing so will prevent the machine from tipping over or falling, which could cause serious injury.
- When the machine is column-mounted on a fryer, make sure the fryer is securely fastened to the floor. If the fryer is not fastened to the floor, the weight of the cutter could cause the fryer to tip over, resulting in serious burns, other injury, or death.
- To avoid damaging the machine, never use force to assemble, disassemble, operate, clean, or maintain it.
- Be careful never to get shortening, water, or other materials on the floor. If anything does get spilled on the floor, clean the area immediately. Materials on the floor can cause people to slip or fall, resulting in serious injury or loss of life.

WARNING

Never put your hand in the hopper or between trip arms while machine is being operated.

DANGER!

When the cutter is column mounted, the fryer must be securely fastened to the floor to prevent tipping or overturning the fryer. If the fryer is tipped, SERIOUS BURNS or other injury can occur.

Operation of this machine is very simple, but there are some details to which we would call your attention in order to get the best results, and keep your machine in perfect running condition.

1. See that all lock nuts are kept tight when running machine.
2. Rotate the crank while the machine is empty and see that it runs freely.
3. Set the pointer on the crank to the center of the dial. To do so, loosen the locknut on the crank, hold the dial and move the crank until the required position is reached, then tighten locknut.
4. When shortening has reached the required temperature, fill the hopper $\frac{2}{3}$ full of dough and crank the machine until it has cut two donuts into the mixing bowl. (This expels any air left in the cutting system).
5. Turn the crank to lowest position which raises the pistons and permits the machine to pass freely over the edge of the kettle. With the machine in position over the kettle, begin turning the crank and moving the machine 3 or 4 inches as each donut is dropped.
6. When the required number of donuts has been dropped, turn the crank again to lowest position and swing machine free of kettle.
7. To regulate the weight of the donuts, move plunger rods to highest position which raises one of the pistons out of the cylinder and allows them to move. The dial pointer can now be set to quantity desired and need not be changed until a different size of donut is desired. To make donuts larger, move pointer toward the "L" on the dial. To make donuts smaller, move dial toward the "S."
8. To use up the last of the dough in the hopper, scrape the dough down around the piston rods, and turn crank slower.
9. The machine should be cleaned as soon as possible after use. Disassemble by reversing the assembly procedure. (See Section 1, Installation).

To facilitate packaging, the Variety Cutter has been partially disassembled and before use it should be cleaned and properly assembled.

1. Wash plunger unit in hot water and detergent, rinse and wipe dry. The plunger should be lightly oiled with cooking oil. **CAUTION:** Never oil donut machine parts by dipping in hot fat, unless thoroughly dry.
2. Remove hopper base from hopper by rotating base approximately $\frac{1}{4}$ turn to release lock pin. Then pull down to remove from hopper. Wash both hopper and hopper base in water and detergent, rinse and wipe dry. The cylinder lining in the hopper base should be lightly oiled with shortening.
3. Wash the crank assembly with a cloth dampened with hot water and detergent. Wipe off with another damp cloth to remove detergent, and wipe dry. **DO NOT IMMERSE THIS UNIT TO WASH OR RINSE.**

Care, Maintenance, and Cleaning for plungers and Hoppers

The plungers and hoppers of your Type K are precision instruments built from alloy steels and aluminum. They should be handled with care to insure continued satisfactory performance.

When cleaning aluminum, selection of the right type cleaner is your most important consideration. Any household dish washing detergent which is safe for aluminum does a good job of cleaning and does not attack aluminum. Strong Alkali cleaners, such as lye, soda ash, and tri-sodium phosphate, will discolor

or even corrode aluminum even in weak solutions.

DO NOT Handle roughly or drop on hard surfaces.

DO NOT Mix with other utensils in the sink when washing.

DO NOT Allow to rust. Always wash parts thoroughly. Dry completely and lubricate with mineral oil or liquid shortening before storing or reinstalling in unit.

DO NOT Force the machine if it becomes jammed. Disassemble and remove any obstruction to prevent damage to the plunger.

Washing Plungers and Hoppers by Hand:

1. Remove plunger from hopper.
2. Use plenty of warm water.
3. Add cleaner approved for aluminum in concentrations recommended by manufacturer.
4. Presoak to loosen stubborn or dried-on deposits.
5. Use a non-scratching plastic scour cloth to remove soil and restore luster.
6. Rinse in clear hot water (170-190 deg.)
7. Wipe completely dry.
8. Dip plungers in mineral oil or liquid shortening to prevent rust and sticking.

NOTE: "O" Rings are not used on plungers for Type K Depositors

Care and Cleaning of Cutters and Dispensers

The most important thing when cleaning aluminum is the selection of the right type of cleaner. Strong alkali cleaners such as lye, soda ash, and tri-sodium phosphate discolor and corrode aluminum, even in weak solutions. A detergent which contains an inhibitor to prevent the attack on metals, such as those listed below, does a good job of cleaning and does not attack the aluminum.

List of Approved Cleaners for Aluminum

1. Aluminum Cleaner NE-6	Enthone, Inc.	New Haven, CT
2. Cascade	Proctor and Gamble	Cincinnati, OH
3. Clenescio A&T	Cowles Chemical Co.	Cleveland, OH
4. Finish	Economics Laboratory	St. Paul, MN
5. Flash-Dri Cleaner	Klenzade Products, Inc.	Beloit, WI
6. Kan Wash	Wyandotte Chemicals	Wyandotte, MI
7. Magnus N Z L	Magnus Chemical Co.	Garwood, NJ
8. Naccanol NR Flakes	National Aniline Division	New York, NY
9. Rinse Aid	Calgon, Inc.	Pittsburgh, PA
10. West Foam Cleaner	West Disinfecting Co.	Long Island, NY

3

Maintenance

Following are some maintenance and operating hints:

- **DO NOT** at any time use force to assemble or operate the machine.
- If machine sticks, disassemble to remove obstruction or check to determine cause and correct same.
- Once each week lubricate the operating cams by putting several drops of oil between trip arms when crank case is held with trip arms pointing up.
- When cleaning machine after use, do not wash or rinse crank case by immersing in water. Use a damp cloth only.

4

Donut Making Helps

Tips on Making Quality Cake Donuts

- Use the correct batter temperature.
In general, the correct batter temperature is 75°-80°F/24°-27°C. Check the mix manufacturer's instructions, as the recommended temperature range may vary.
If the batter is too warm, the donuts will lack volume and may "ring out" or be misshapen. If the batter is too cold, the donuts will stay under the shortening too long, fry too slowly, and crack open or ball up. They may also absorb excess shortening and lose volume.
- Use the correct floor time.
A floor time of 10 minutes between mixing and cutting allows the baking powder to react with the water. This helps the donuts attain the proper volume and absorb the proper amount of shortening.
If the floor time exceeds 30 minutes, the mix will gas off, the donuts will lose volume and shape and will absorb too much shortening.
- Use the correct frying temperature.
The correct shortening temperature for frying is 370°-380°F/188°-193°C.
If the shortening is too hot, the donuts will fry too quickly on the outside and will lose volume. The donuts may also become dense inside.
If the shortening is too cold, the donuts will spread too rapidly, will form large rings, will tend to crack open, will be too light in appearance, and will absorb too much shortening.

- Maintain the proper shortening level. We recommend a distance of 1 1/4" between the cutter and the shortening.

If the shortening is too deep, the donuts may not turn over when they reach the turner, causing them to cook unevenly.

If the shortening is too shallow (too far below the cutter), the donuts may not drop flat, may turn over while submerging and surfacing, and may become irregular, cracked, or rough-cruled.

- Ensure that the donuts absorb the right amount of shortening.

Donuts should absorb 1-1/2 to 3 oz/42 to 85 g of shortening per dozen, depending on their weight. You can achieve proper absorption by following tips 1-3.

- If the donuts do not absorb enough shortening, they will not keep well.

If they absorb too much shortening, they will lose volume and may become misshapen. If this happens, follow tips 1-3, mix the batter a little longer than usual, turn the donuts as soon as they become golden brown, and turn the donuts only once.

TABLES AND FORMULAS USED IN DONUT MAKING

Calculating Correct Water Temperature

The following is an example of how to calculate the correct water temperature to use. You must use your own room temperature, dry mix

temperature, desired batter temperature, and, if you are making yeast-raised donuts, estimated temperature increase during mixing.

	Cake Donuts		Yeast-Raised Donuts	
	°F	°C	°F	°C
Room temperature	72	22.2	72	22.2
Dry mix temperature	<u>+70</u>	<u>+21.1</u>	<u>+70</u>	<u>+21.1</u>
Total A	142	43.3	142	43.3
Desired batter temperature	75	23.9	80	26.7
	<u>x3</u>	<u>x3</u>	<u>x3</u>	<u>x3</u>
Total B	225	71.7	240	80.1
Total B	225	71.7	240	80.1
-Total A	<u>-142</u>	<u>-43.3</u>	<u>-142</u>	<u>-43.3</u>
Desired water temp. for cake donuts	83°F	28.4°C	98	36.8
			↓	↓
		Figure from above	98	36.8
Temperature increase during mixing (average: 30°F/17°C)			<u>-30</u>	<u>-17</u>
Desired water temperature for yeast-raised donuts			68°F	19.8°C

Ratios of Plunger Sizes to Donut Weights

The weights given are for donuts without icings or other toppings. They are provided for reference only, as weights vary according to the density of the batter.

Plunger Size	Donut Weight per Dozen
1"	5-8 oz/142-227 g
1 7/16"	10-17 oz/283-482 g
1 9/16"	14-21 oz/397-595 g
1 13/16"	19-23 oz/539-652 g

Temperature Conversion

To convert temperatures from Fahrenheit to Celsius, subtract 32 from °F and divide the result by 1.8. For example, $212^{\circ}\text{F} - 32 / 1.8 = 100^{\circ}\text{C}$. To convert temperatures from Celsius to Fahrenheit, multiply °C by 1.8 and add 32 to the result. For example, $(100^{\circ}\text{C} \times 1.8) + 32 = 212^{\circ}\text{F}$.

°F	°C	°F	°C
212	100.0	355	179.4
325	162.8	360	182.2
330	165.6	365	185.0
335	168.3	370	187.8
340	171.1	375	190.6
345	173.9	380	193.3
350	176.7	385	196.1

Batter Temperature Chart (Fahrenheit)

Flour Temperature	Water Temperature
55°F	89°F
56°F	88°F
57°F	87°F
58°F	86°F
59°F	85°F
60°F	84°F
61°F	83°F
62°F	82°F
63°F	81°F
64°F	80°F
65°F	79°F
66°F	78°F
67°F	77°F
68°F	76°F
69°F	75°F
70°F	74°F
71°F	73°F
72°F	72°F
73°F	71°F
74°F	70°F
75°F	69°F
76°F	68°F
77°F	67°F
78°F	66°F
79°F	65°F
80°F	64°F

- If flour temperature is above 80°F, use ice water.
- If shop is extra cold, add 2°F to indicated water temperature.
- If shop is extra warm, subtract 2°F from indicated water temperature.

Belshaw[®]

Cake Donut Cutter

Type N



Technical Supplement

Belshaw Adamatic Bakery Group
814 44th Street Northwest, Suite 103
Auburn, WA 98001 USA
1-800-BELSHAW • 800-578-2547 • (1) 206 322-5474 •
service@belshaw.com • www.belshaw.com

Contents

TECHNICAL SUPPLEMENT

<u>5</u>	<u>Assembling the Cutter</u>	<u>16</u>
<u>6</u>	<u>Cut-N-Fry Installation with Type N and 616B Fryer</u>	<u>17</u>
	Mounting Instructions	17
<u>7</u>	<u>Wall-Mount Installation</u>	<u>19</u>
	Wall mount installation	19
<u>8</u>	<u>Maintenance</u>	<u>20</u>
	Operation and Maintenance hints:	20
<u>9</u>	<u>Parts List and Diagrams</u>	<u>20</u>

Preface

The Type N Variety Cutter is designed to cut cake donut products and deposit them in a variety of smaller fryers. It is designed to be mounted on a wall or on a fryer mount.

During production, the operator must move the Cutter, holding the guide handle, to deposit donuts in the desired locations in the fryer. The operator must work safely at all times and read this manual and follow its instructions and warnings.

A thorough understanding of how to install, maintain, and safely operate the Type N Variety Cutter will prevent production delays and injuries. Heed the following warnings and all other warnings that appear in this manual:

- Make sure the machine is mounted securely. Doing so will prevent the machine from tipping over or falling, which could cause serious injury.
- When the machine is column-mounted on a fryer, make sure the fryer is securely fastened to the floor. If the fryer is not fastened to the floor, the weight of the cutter could cause the fryer to tip over, resulting in serious burns, other injury, or death.
- To avoid damaging the machine, never use force to assemble, disassemble, operate, clean, or maintain it.
- Be careful never to get shortening, water, or other materials on the floor. If anything does get spilled on the floor, clean the area immediately. Materials on the floor can cause people to slip or fall, resulting in serious injury or loss of life.

WARNING

Never put your hand in the hopper or between trip arms while machine is being operated.

DANGER!

When the cutter is column mounted, the fryer must be securely fastened to the floor to prevent tipping or overturning the fryer. If the fryer is tipped, SERIOUS BURNS or other injury can occur.

5

Assembling the Cutter

1. Position hopper on the small bracket arm setting mounting hole over the bracket pin.
2. Insert hopper base in bottom of cylinder, pushing up to force lock pin out. When hopper base is fully inserted, rotate until lock pin goes into place.
3. Position crank case on the double locating studs. Do not push the crank case fully into position, holding back approximately $\frac{1}{2}$ ". Start the lock nut on the end of the threaded locating pin.
4. Insert the plunger by passing rods through the opening in the hopper center and having the plunger bearing above the hopper arch. Lower the plunger bearing into the bearing seat in the hopper center. Align the arms with the plunger pins. When the forks on the trip arms are in line with the plunger pins, tighten the crank case locknut which pushes the crank case into position. Then tighten lock screw on the hopper center bearing to hold plunger bearing in place.

6 Cut-N-Fry Installation with Type N and 616B Fryer

This section shows how to mount a Type N depositor with your 616B fryer to form a Cut-N-Fry combination.

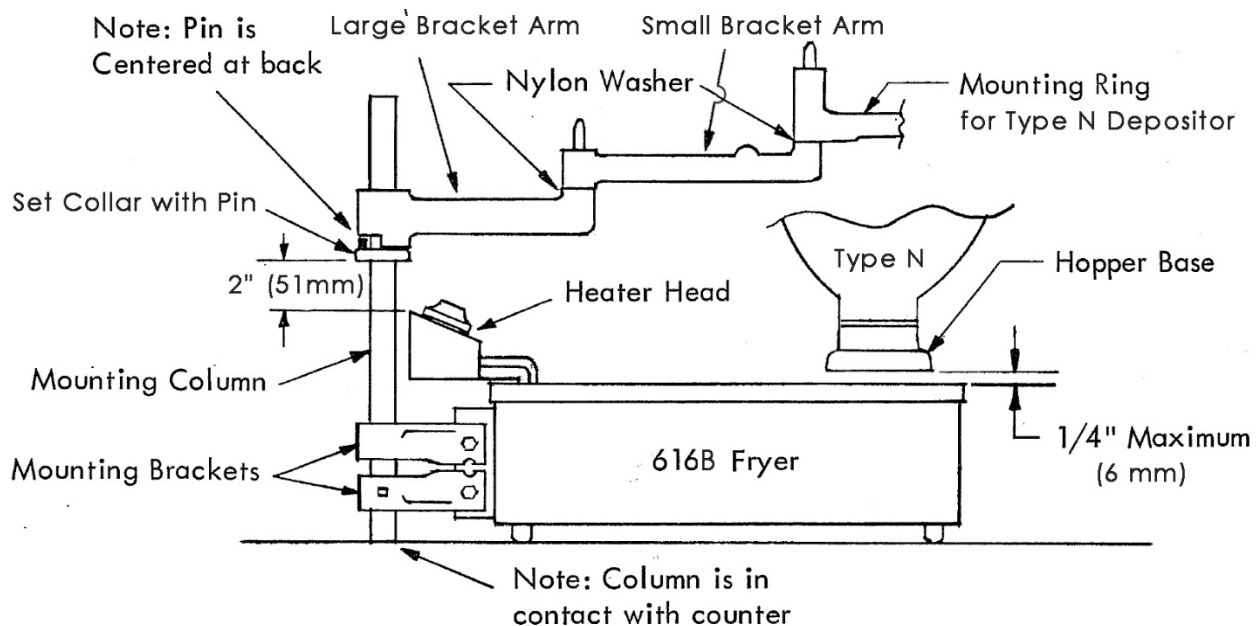

SAFETY NOTICE

The cut-n-fry unit should be located on a solidly constructed countertop with the heater head toward the wall. When the unit is not mounted near the wall and is accessible from all sides, the 616B fryer should be bolted to the table (or other surface that supports it). A hole can be drilled through the bottom of the outer case, after removing the kettle.

Mounting Instructions

1. Mount the **Mounting Brackets** at the rear of the 616B FRYER.
 - Fasten securely to the metal block using the included 1/4 inch bolts.
2. Place the **616B Fryer** in the position where it will be used, and slide the **Mounting Column** into place.
 - The column should rest on the counter top surface. Tighten the set screws in the mounting brackets.

3. Place the **Set Collar with Pin** onto the column as shown, approximately 2 inches (51mm) above the **Heater Head** of the fryer.
 - The pin should point upward. Tighten the set screw securely. Oil the column above the set collar with light machine oil.
4. Slide the **Large Bracket Arm** onto the **Mounting Column** until it rests on the **Set Collar With Pin**.
 - Oil the pin slightly and install the **Nylon Washer**.
5. Place the **Small Bracket Arm** onto the pin of the Large Bracket Arm.
 - Oil the pin slightly and install the **Nylon Washer**.
6. The **Hopper Base** of the Type N Depositor will be mounted on the pin of the **Small Bracket Arm**.
 - The bottom of the depositor should be 1/4" (6 mm) above the rim of the **616B Fryer**

7

Wall-Mount Installation

This machine is designed to be used on either a wall mount or a fryer mount. This should be specified when the machine is ordered from the factory. If the mounting is not specified, the fryer mount will be shipped.

Wall mount installation

It is necessary to provide a good solid support for mounting the machine to the wall. We suggest the use of a 2 x 4" timber, securely fastened to the wall. This 2 x 4 should be long enough to extend upward from the floor to a distance approximately 18" higher than the top of the frying kettle.

If the wall is wood, the 2 x 4 should be securely spiked to the wall. If the wall is brick, holes should be drilled, and the 2 x 4 fastened by lag bolts with expansion bolt shields.

1. Set the frying kettle in position directly in front or a little to the right of the wall support, and approximately 6" from the wall. The Variety Cutter can be mounted from either side of the kettle or between 2 kettles.
2. Lay a straight edge, (a board will do) across the kettle top to the 2 x 4.
3. Measure up 9" and mark center which will be the correct height and position for the top hole in the wall plate. Drill a 1/4" hole at this point and fasten the wall plate with the lag screws which come with the machine.

4. Determine the correct vertical position of the wall plate, then screw the plate down securely to the 2 x 4 using all 6 screws.
5. To locate the curved arm section in place on the wall plate, the large bushing should be installed in the curved arm section. The set collar should be installed on the large bushing under the curved arm. Then slide the 1/2" pin through the upper bearing hole on the wall plate, through the bushing and then through the lower bearing hole on the wall plate. Place washer provided on the upright pin to serve as a thrust bearing. Oil pin lightly with light machine oil.
6. Set the small straight arm in place on the pin of the first bracket arm. This should be also mounted so that the pin is pointing up. Place 1/2" washer provided on the pin. Oil pin lightly with light machine oil.
7. The donut cutter should be mounted on the pin of the straight arm. Adjust the set collar under the curved arm to give the proper clearance. (A) The guard flange of the hopper base when mounted on the machine should just clear the rim of the fryer. (B) The bottom of the cutter should be 1" to 1 1/4" from the surface of the shortening.

8

Maintenance

Operation and Maintenance

hints:

- **DO NOT** at any time use force to assemble or operate the machine.
- If machine sticks, disassemble to remove obstruction or check to determine cause and correct same.
- Once each week lubricate the operating cams by putting several drops of oil between trip arms when crank case is held with trip arms pointing up.
- When cleaning machine after use, do not wash or rinse crank case by immersing in water. Use damp cloth only.

9

Parts List and Diagrams

See following pages.

Parts List Drawing Insert Page

Title: N Cake Donut Cutters

Model: N

Item Number: N20000 N-LB-LP-LG

Final Assembly Drawing: N20000 Mechanical Assembly BOM Only

Sub Assemblies: N-1001 Cutter Head Assembly
N-0506 Cyl Retainer Pin Assy-lg Bore

OPTIONAL MOUNTING KITS

Wall Mount: N-1036 Type N Wall Mt Kit

Column Mount: N-1033 N Short Col Mt Kit

(MM) Single Level Bill of Material - N20000 N LG BORE LESS BRKT,PLGR,CYL Site: PRI
Belshaw Primary Production Rev:

Component	Description	Qty per	Primary
N-0030	THUMB NUT	1.000	Yes
N-0506	CYL RETAINER PIN ASSY-LG BORE	1.000	Yes
N-1001	CUTTER HEAD ASSY	1.000	Yes
N-1002L	HOPPER ASSY LG BORE	1.000	Yes

BILL OF MATERIAL	
CODE	DESCRIPTION
(1)	N-19 CAM CASE COVER ASSY.
(2)	N-34 OUTBOARD BEARING CARRIER ASSY.
(3)	N-5 SHAFT CAM ASSY.
(4)	N-15 CAM ROLLER ASSY.
(5)	21 PEG KEY
(6)	MKX-0025 TRIP ARM ASSY. - UPPER
(7)	MKX-0024 TRIP ARM ASSY. - LOWER
(8)	N-15 TRIP ARM PIVOT
(9)	N-6 SLEEVE CAM
(10)	N-1019 GUIDE HANDLE PIN
(11)	624-152 HANDLE
(12)	N-1 CAM CASE ASSY.
(13)	170N DIAL CLAMP BOLT
(14)	N-63 QUAD RING SEAL
(15)	N-1004 DIAL & HUB ASSY.
(16)	N-62 REAR COVER-CAM CASE
(17)	125 DIAL LOCK NUT
(18)	N-502 CRANK HANDLE ASSEMBLY
(A)	3 4-40 X 3/8 SLOTTED PAN HD. SELF-TAPPING SCREW
(B)	2 1/4-20 HEX NUT
(C)	2 5/16-18 X 1/2 FLAT POINT SET SCREW
(D)	2 6-32 X 1/4 SLOTTED RD. HD. MACH. SCREW

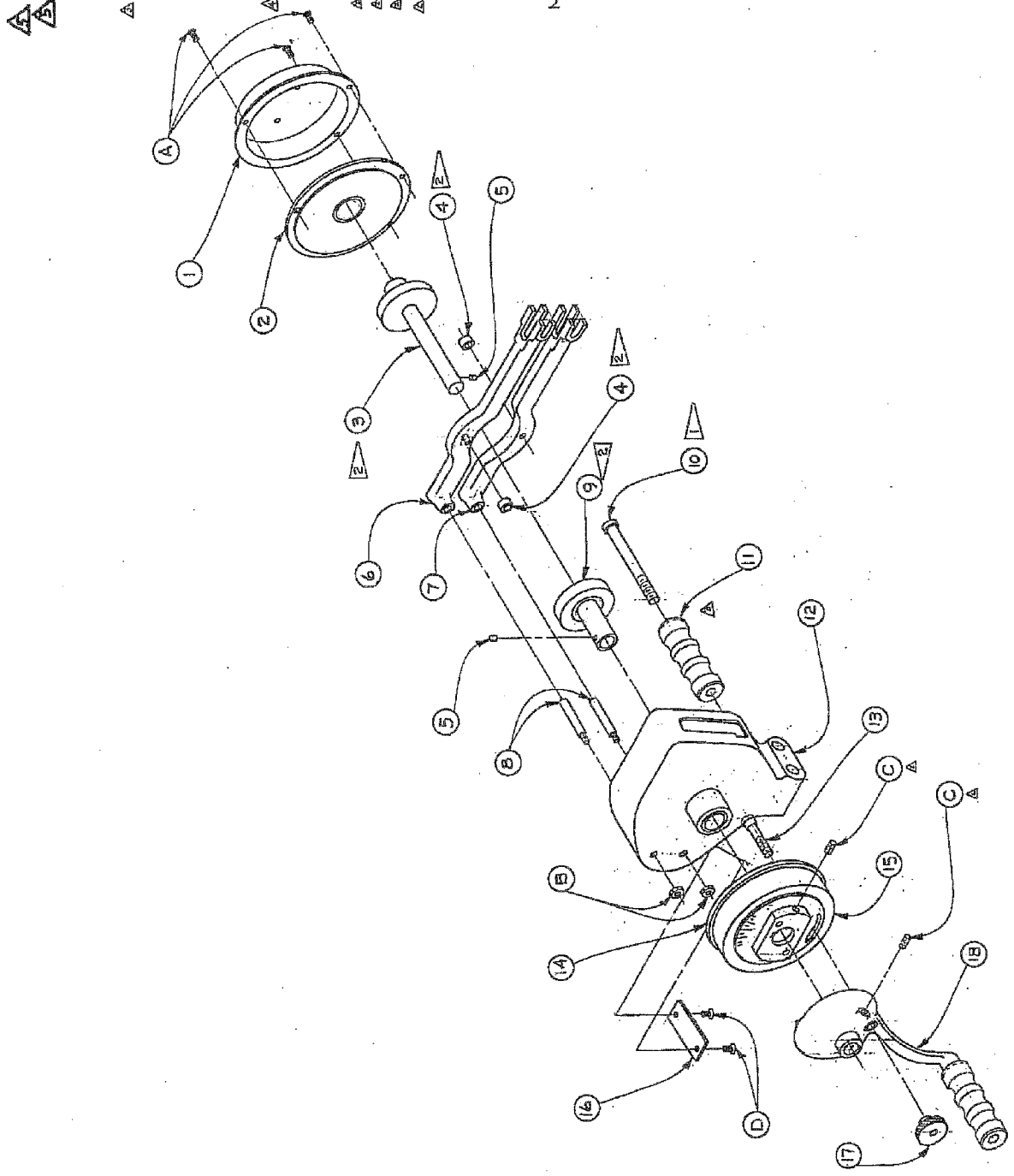

NOTES:
 ▲ APPLY LOCTITE TO THREADS WHEN ASSEMBLING.
 ▼ APPLY LUBRICATING GREASE WHEN ASSEMBLING.

ORIG. DWG.

QTY	ASSEMBLY	REVISION	DATE	APPR.	DATE	TRK.	DATE
1	N-2000	A	11-21-81	JAM	11-21-81	DEC.	11-21-81
1	N-2001	A	12-30-82	JAP	12-30-82	APR.	12-30-82
		A	12-30-82	JAP	12-30-82	MAY	12-30-82
		A	12-30-82	JAP	12-30-82	JUN	12-30-82
		A	12-30-82	JAP	12-30-82	JUL	12-30-82
		A	12-30-82	JAP	12-30-82	AUG	12-30-82
		A	12-30-82	JAP	12-30-82	SEP	12-30-82
		A	12-30-82	JAP	12-30-82	OCT	12-30-82
		A	12-30-82	JAP	12-30-82	NOV	12-30-82
		A	12-30-82	JAP	12-30-82	DEC	12-30-82

SCALE	DRAWN	APPROVED	DATE	DRAWING NUMBER
	J.C.	MCM	10-25-82	N-1001

COMPANY	TITLE	LOCATION
BELSHAW BROS., INC.	CUTTER HEAD ASSEMBLY	Seattle, Washington

ASSEMBLY PARTS

DESCRIPTION

PART NO.

QTY.

EXTENSION SPRING

N-26C

2

CYLINDER RETAINER PIN - SHORT

N-70SH

2

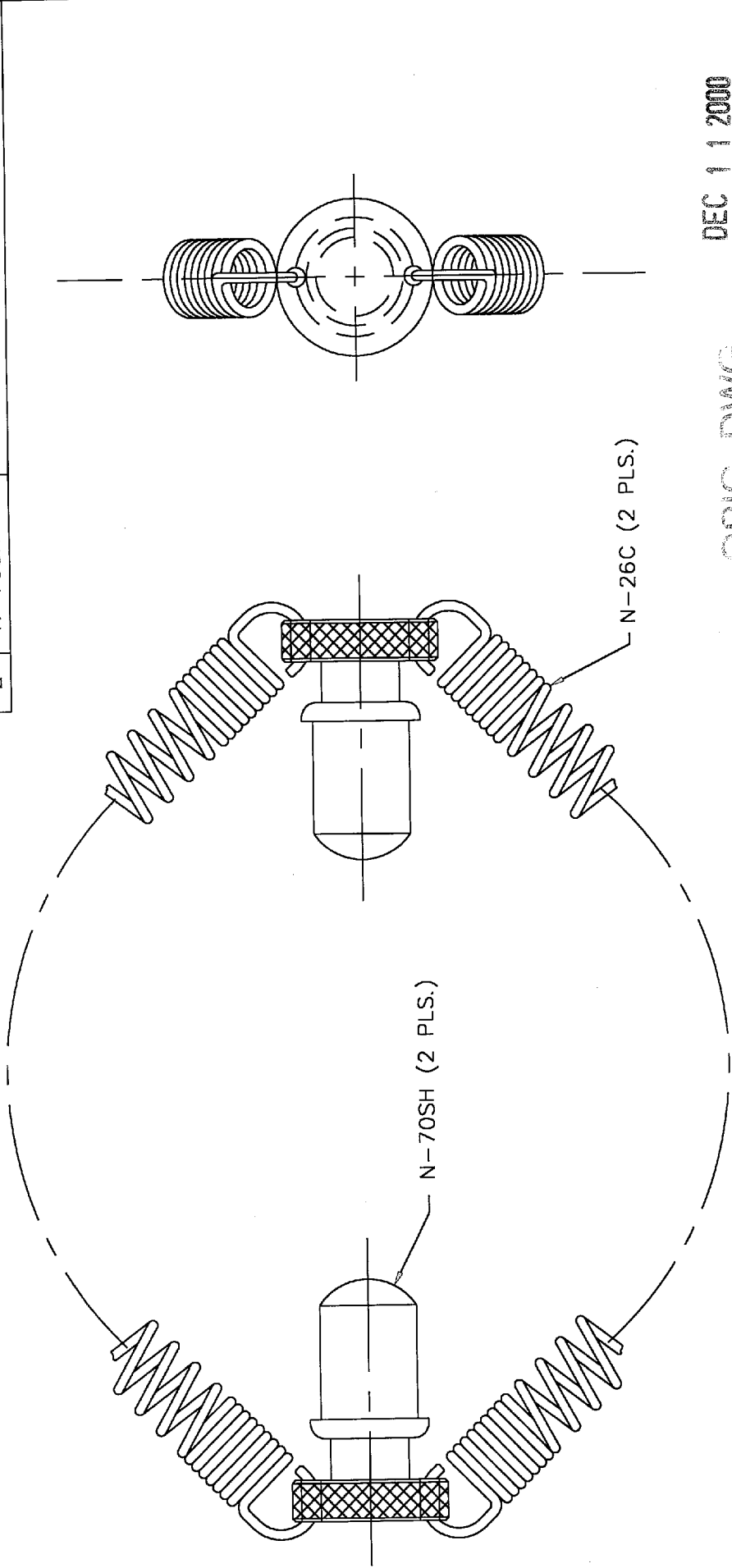

DEC 1 1 2000

ORIG. DWG.

BELSHAW BROS., INC.
SEATTLE, WASHINGTON

TITLE: CYLINDER RETAINER PIN ASSEMBLY-DUAL

MATERIAL:

N-506

DRAWING NO.:

06-26-95 DATE:

APP'D.:

MCM DRAWN:

2=1 SCALE:

QTY.	ASSEMBLY NO.	REVISION/DATE	APP'D.	TOL. UNLESS NOTED
1	N-2001	ADD U/O AB 12/8/00	LCP	DECIMAL ±.010
1	MKIX-1001			FRACTION ±1/32
				ANGLES ±1/2°
				DWG. SIZE A

KIT CONSISTS OF:

QTY.	PART NO	DESCRIPTION
(1)	121	SET COLLAR ASSY
△ (1)	132-2	COLUM
(2)	N-44	THRUST WASHER
(1)	N-47	COLUMN ARM ASSY.
(1)	N-48	PIVOT ARM ASSY.
(1)	616-60	COLUMN MTG. BRACKET
		<u>FASTENERS</u>
		(2) 5/16-18X1 HEX HD PACH SCREW
		(1) 5/16-18X1/2 SQ HD SET SCREW
		(2) 5/16-18X7/8 SQ HD SET SCREW

...DWG

ASSEMBLY		REVISION / DATE		APP		TOL'S UNITS NOTED		BELSHAW BROS., INC. Seattle, Washington	
AS REQ'D		△ DELETED 132-2 5-21-82		MM		DEC. ± .010		TYPE "N" COLUMN MTG BRKT. KIT (SHORT)	
		△ ADDED TO DRAWING 12-29-90		MM		ANG. ± 1/2°		TITLE	
						FRACT. ± 1 / 32		MATERIAL	
						SCALE		A1F DRAWN	
								APPROVED	
								11-9-76 DATE	
								DRAWING NUMBER N-1033	

KIT CONSISTS OF:

<u>QTY</u>	<u>PART NO</u>	<u>DESCRIPTION</u>
(1)	4	WALL PLATE
(1)	11	WALL ARM PIN ASSY
(1)	120	WALL ARM SECTION BUSHING
(1)	121	SET COLLAR ASSY
(1)	N-22	COLUMNARM ASSY
(1)	N-23	PIVOT ARM
(2)	N-44	THRUST WASHER
(1)	N-53A	PIVOT ARM YOKE ASSY
(1)	N-54	YOKE PIN ASSY

FASTENERS

- (6) 5/16X1 1/2 HEX HD LAG SCREW
- (1) 5/16-18X1 1/2 SG HD SET SCREW

DATE: 11-10-16

QNTY	ASSEMBLY	REVISION / DATE	APY	TOL'S UNLESS NOTED	BELSHAW BROS., INC.	Seattle, Washington
	AS REQD			DEC. ± .010	TYPE 'N' WALL MTG BRACKET KIT	
				ANG. ± 1/2°	TITLE	
				FRACT. ± 1/32	MATERIAL	
				SCALE	DRAWN	APPROVED
					A.F.	SGB
					DATE	DATE
					11-10-16	11-10-16
					DRAWING NUMBER	DRAWING NUMBER
					N-1036	N-1036

Belshaw Adamatic Bakery Group Limited Warranty / Return Policy

Subject to the terms and limitations set forth in this limited warranty ("Limited Warranty"), Belshaw Adamatic Bakery Group (also referred to as "the Manufacturer") warrants to the original purchaser ("Purchaser") of Manufacturer's equipment and parts ("Products"), Belshaw Adamatic Bakery Group's manufacture and assembly of Products to be free from defects in workmanship and material which would result in product failure under normal use and service. Belshaw Adamatic Bakery Group's entire liability under this Limited Warranty is limited to either repairing or replacing at Manufacturer's factory or on Purchaser's premises, at Belshaw Adamatic Bakery Group's option, any Products purchased by Purchaser which shall be determined by the Manufacturer to be defective. If necessary to return Products to Manufacturer's factory, Products must be shipped by Purchaser with transportation charges prepaid by Purchaser.

Belshaw Adamatic Bakery Group reserves the right to make changes in design or add any improvement to its Products at any time without incurring any obligations to install the same on Products previously sold.

Possession, use or operation of Products sold hereunder for any other than their designed purpose, or use of Products which are in poor repair, modified, improperly operated, or neglected, is done at the Purchaser's risk. Belshaw Adamatic Bakery Group hereby disclaims any liability for these actions and shall not be liable for defects in or for any damages or loss to any property which is attributable to such actions.

Under no circumstances shall Belshaw Adamatic Bakery Group be liable for any indirect, special, incidental, or consequential damages arising out of, or from the use of its Products by Purchaser, its assignees, employees, agents or customers.

THIS LIMITED WARRANTY SHALL BE PURCHASER'S SOLE AND EXCLUSIVE REMEDY WITH RESPECT TO DEFECTIVE PRODUCTS.

Warranty Period

This Limited Warranty covers Products manufactured by Belshaw Adamatic Bakery Group and sold by Belshaw Adamatic Bakery Group or its authorized distributor ("Distributor") or authorized dealer ("Dealer"), and this Limited Warranty shall extend for a period of one (1) year from date of shipment to Purchaser, and to the original Purchaser only.

Limited Warranty

With respect to products not manufactured by Belshaw Adamatic Bakery Group, warranty coverage shall be limited to the warranty of the original manufacturer of the product, or the Belshaw Adamatic Bakery Group Limited Warranty, whichever is the lesser coverage period.

Replacement Products provided under the terms of this Limited Warranty are warranted for the remainder of the original warranty period applicable to the Product.

Exclusions

This Limited Warranty excludes from its coverage and does not apply to: (a) solenoid and relay coils; (b) lamps; (c) "O" rings; (d) belts; and (e) impellers. This Limited Warranty also excludes the cost of labor for removing and replacing Products subject to a warranty claim, other than the labor incurred directly by the Manufacturer when, in Belshaw Adamatic Bakery Group's opinion, a repair of the Product by the Manufacturer is justified.

Warranty Claims

In case of warranty claims relating to your Product, you must follow the instructions below.

Report Claims to Your Authorized Distributor or Dealer or to Belshaw Adamatic Bakery Group

As soon as you discover a problem, contact the Distributor or Dealer from whom you purchased the Product or Belshaw Adamatic Bakery Group. Your Distributor or Dealer will notify Belshaw Adamatic Bakery Group for you. **Only Belshaw Adamatic Customer Service can approve or authorize warranty claims.**

You must state the following:

1. Your name, company name, and telephone number
2. The location, phone number, and contact name where the Product is located
3. The invoice number and date of purchase of the Product
4. The Model and Serial Number of the Product, as written on the data tag attached to the Product
5. A description of the problem and how it occurred

Shipping Damage and Missing Items

Damage to the Packaging or Crate. On delivery, promptly check all packages thoroughly for any sign of damage. In cases of visible damage, **always note the damage on the Delivery Receipt.** Failure to note damage is taken by the Freight Carrier to mean that the package is in good condition at time of receipt, and can result in denial of a Freight Claim. Take photographs that clearly show the damage.

Damage to Products. If you find any damaged Product inside the shipment, photograph the damage both inside and outside of the package. Do not throw the packaging away. Photos of the package and contents are needed to show the condition of the Product at the time it was received.

Missing Items. As soon as you believe any items to be missing from a shipment, promptly report this to the Distributor or Dealer from whom the Product was purchased or to Belshaw Adamatic Bakery Group. If possible, photograph the entire contents of the delivery and email this to your Distributor or Dealer, or to Belshaw Adamatic Customer Service at service@belshaw.com.

Returning Products to Belshaw Adamatic Bakery Group

Under the terms of the Limited Warranty, you may be asked to return to Belshaw Adamatic Bakery Group any Product that is the subject of a warranty claim. These Products must be clearly labeled with a Return Goods Authorization Number ("RGA Number") given to you by your Distributor or Dealer, or by Belshaw Adamatic Customer Service. Products received without an RGA Number will not be processed. All Products must be shipped freight prepaid by the Purchaser to Belshaw Adamatic Bakery Group at the address below.

Contacting Belshaw Adamatic Bakery Group

At any time, you can contact Belshaw Adamatic Bakery Group customer service for assistance

Belshaw Adamatic Bakery Group Customer Service

814 44th St. NW, Suite 103,

Auburn WA 98001, USA

Phone: 800-578-2547 (USA/ Canada) or (+1)206-322-5474 (Worldwide)

Email: service@belshaw.com

Office Hours: Monday – Friday, 6am to 4pm, USA Pacific Time