



Fresh **Answers**
for today's bakery.

COMBINATION CONVECTION/DECK OVEN

Belshaw's Combination Convection/Deck Oven offers bakeries exceptional flexibility and versatility in a compact package.

The 3-pan wide, 2-deck, modular-deck-oven features a heavy-duty reinforced single-stone hearth on each deck. This heavy-duty hearth provides the oven with excellent thermal retention properties. You'll enjoy the "old world" baking characteristics.

The unique self-contained steam system features elements that are not exposed to water as well as 3 steam exit ports. A large volume of steam can be generated and evacuated quickly, and no drain is required. The steam system is standard and there is no associated "power" charge for it.

The controller on the deck oven is easy to operate and features a 7-day auto-on control and independent control of upper, lower and front heat.

The Combination Convection/Deck Oven also features two 4-pan BX convection ovens. BX air-flow and moisture management systems are designed to produce an even bake that you just can't find on other foodservice convection ovens. Steam capability comes standard on all BX ovens. The system features a high-velocity water fracturing system that provides high-quality steam on-demand. Rapid water vaporization forces water to enrobe the baked product and enables good control over crust depth, coloration and shine.

BX ovens feature two electronic programmable controller choices. The Classic controller is capable of storing up to 9 different programs. The state-of-the-art Smartbake controller provides a color display, storage of up to 99 programs and is perfect for exhibition-style baking. BX ovens are designed to accommodate industry standard 18"x26" trays.



Belshaw Combination Convection/Deck Oven

Features Summary

Deck Ovens

- ❑ Single-piece, heavy-duty, stone hearth
- ❑ Patented self-contained steam system
- ❑ Double-pane, full width/height viewing windows
- ❑ Each deck independently operated
- ❑ Stand with locking casters
- ❑ Canopy with 950 cfm fan

Convection Ovens

- ❑ Bakes evenly
- ❑ Steam capability standard
- ❑ Choice of 2 electronic programmable controllers
- ❑ "Cool to touch" door technology

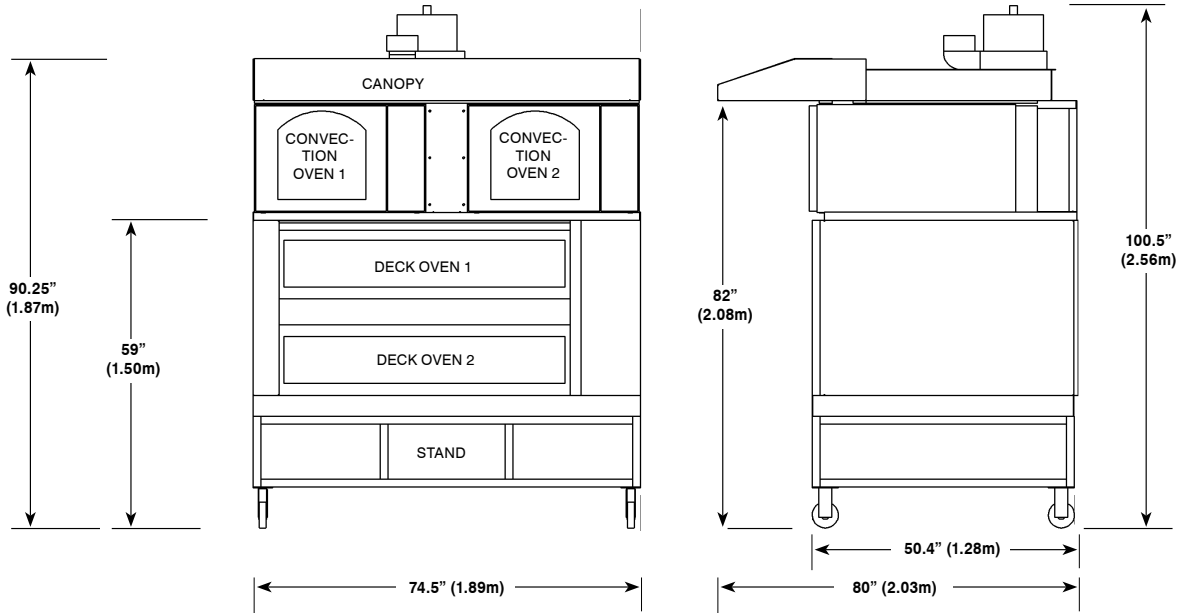

Dimensions

Overall width	74.4" (1.89m)
Overall depth	50.4" (1.28m) base 80" (2.03m) with canopy overhang
Overall height	100.5" (2.56m)
Headroom under canopy overhang	82"
Heated area width (deck ovens)	55.9" (1.42m)
Heated area depth (deck ovens)	32.3" (82cm)
Heated area height (deck ovens)	7.25" (185mm)
Height of convection ovens	59.1" (bottom) - 82" (top)
Recommended clearance	12" (30cm) for cooling and service access.

Electrical and Water Hookup

	DECK OVEN (per oven)	CONVECTION OVEN (per oven)	CANOPY (6" Round duct / 950cfm)
Power	208 V/60hz/3ph 25 A	208 V/60hz/3ph 40A	208V/240/60hz/1ph 6A
Cord supplied	3ph+Neutral+Ground 108" (2.75m)	3ph+Neutral+Ground 108" (2.75m)	108" (2.75m) without plug
Water supply	30-45 PSI	30-45 PSI	N/A

IMPORTANT: The electrical and water hookups shown above are needed for each deck and convection oven, individually.