



CONVECTION OVENS

BX4 • BX10 • BX Proofer

BX Ovens

Belshaw's BX Convection Ovens are designed and manufactured specifically for producing high-quality baked goods. The BX series is available in 4-tray and 10-tray configurations and is ETL-listed for safety and sanitation. Air flow and moisture management systems ensure the BX oven produces a high-quality, even bake – time after time.

The internal oven configuration and fan design are the keys to the air flow management system. These features allow high egg-content products to develop proper cell structure and reduce the likelihood of drying baked-products out.

The moisture management system features a high-velocity water-fracturing system that provides high-quality steam on demand. Rapid water vaporization forces moisture to enrobe the baked product and enables fast gel-paste formation on its surface. The result is good control of crust depth, shine, and coloration. Furthermore, the moisture acts as a vehicle for heat transmission to the product interior which promotes an even-bake and extends shelf-life.

Belshaw's BX Oven features two options for electronic programmable controllers — the Classic and the SmartBake.

The Classic Controller is capable of storing up to 9 different programs. The programmer can preset bake temperature, bake time, steam duration, and damper duration.

The state-of-the-art SmartBake Controller allows for more flexible and sophisticated baking programs. The controller is capable of storing up to 99 six-phase baking programs. Different settings for bake temperature, power level, steam time, fan direction, and damper duration are possible for each phase. The SmartBake Controller can also be programmed for full or half-loads and provides large, color, alphanumeric and graphical displays — perfect for exhibition baking.

BX Ovens are fitted with vented doors with 'cool to touch' double glazing. Air flow between the panes provides cooler glass and surrounding metalwork and saves energy by reducing heat loss.

BX4-2618-Classic (4-tray) ▶



◀ BX4-2618-Smartbake (4-tray)



BX10-2618-S (10-tray) ▶



◀ BX4-2618-C + BX Proofer

Features Summary – Ovens

- ❑ Produces an even bake.
- ❑ Steam injection is standard on all ovens.
- ❑ 2 programmable controller options.
- ❑ Compatible with 18" x 26" trays
- ❑ BX4 ovens are stackable.
- ❑ BX10 ovens include stand and casters.
- ❑ 'Cool to Touch' oven-door technology.
- ❑ ETL listed

Proofer and Stand

- ❑ Blower system for evenly circulating warm humid air.
- ❑ Thermostat-controlled dry heat and wet heat.
- ❑ 8-tray capacity
- ❑ Stainless steel and aluminum construction.
- ❑ Heating unit readily removeable for thorough cleanup.
- ❑ Auto-water optional

SmartBake Controller

Up to 99 programs. Six phases possible in each program. For each phase, you control:

- Phase time
- Bake temperature
- Power level (permits control of oven chamber air velocity in conjunction with temperature).
- Steam injection on/off.
- Fan cycles. Fan can reverse direction up to 9 times per phase.
- Damper open/shut.



Programs are set through control panel or via download from computer. Prominent countdown timer and audible signal at end of program.

Classic Controller

Up to 9 programs. For each program, you control:

- Bake time
- Oven temperature
- Steam duration
- Damper duration

Settings can be changed while the program is running. Programs are set on control panel.



PLAN DIMENSIONS

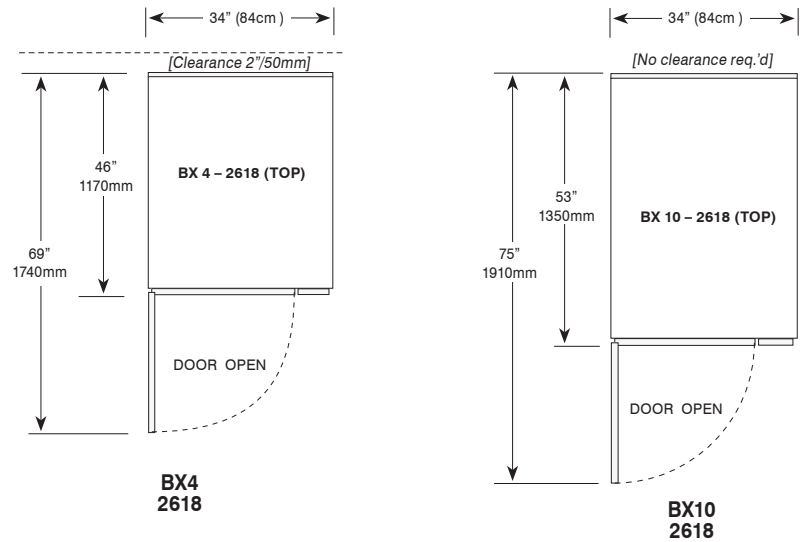

TYPICAL HEIGHTS (See also table below)

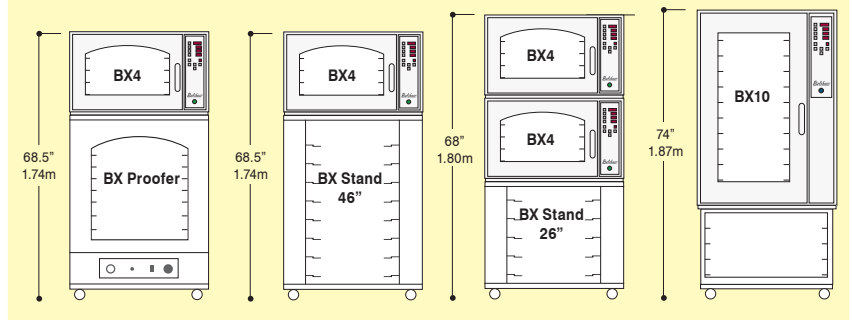

MODEL	TRAYS			DIMENSIONS			WEIGHT	ELECTRICAL		
	Trays	Tray size	Shelf height	Height	Width	Depth	Shipping Class=85	Volts	Amps	Wiring
BX-4 – 2618	4	18" x 26"		21" (53cm)	34" (84cm)	46" (1.17m)	370lbs (168 kg)	208V/60/3ph	24 A	3 + N + G
BX-10 – 2618	10	18" x 26"		74" (1.87m)	34" (84cm)	53" (1.35m)	982lbs (446 kg)	208V/60/3ph	58 A	3 + N + G
BX PROOFER	8	18" x 26"		46" (1170mm)	39.5" (1000mm)	35.5" (905mm)	111kg (243 lbs)	208V,60hz,1ph	10 A	2 + G

IMPORTANT (1) Standard cord 6ft/1.8m (2) Damper: butterfly type (3) Water Supply: min 30 PSI (2 bar) at the oven (4) Clearance 18" (450mm) above oven (unless stacked); 2" (50mm) at back and sides.