



The worldwide leader in donut production equipment

+1.206.322.5474 • info@belshaw.com • www.belshaw.com



## CAKE DONUT DEPOSITORS

Type 'B' • Type 'F' • Type 'N' • Donut Robot®

Belshaw's Donut Depositors, the industry standard for over 75 years, are legendary for their precision and smoothness of operation - even after years of use in harsh conditions.

Each Donut Depositor is engineered of durable gears, cams and trip arms that ensure identical volume and shape are produced with each and every deposit. Large swing arms enable precise positioning above the fryer with almost no effort. All units are mountable on a circular column or directly onto a wall.

Belshaw **Type 'B'** Donut Depositor is a mechanically assisted, hand crank machine designed for open kettle fryers of any make/model. The Type 'B' holds 15 lbs (7 kg) batter weight, and accepts all 10 Belshaw donut plungers and attachments, each forming one or more cake donut varieties. The Type B typically deposits 60 to 100 donuts per minute.

Belshaw **Type 'F'** Donut Depositor is equivalent in size to the Type 'B', but utilizes a motor and touch-sensitive handle to deposit at a rate up to 115 strokes per minute. The faster stroke rate and easier operation of the Type 'F' reduces frying time variability between the first and last donuts dropped into the fryer, particularly for larger fryers, and is physically easier on the operator. The "Deluxe" option features a highly polished aluminum body.

Belshaw **Type 'N'** Donut Depositor holds 12 lbs (5 kg) batter weight and is used with smaller fryers such as Belshaw's 616 tabletop fryer. The **Automatic Type 'N'** is designated for use with Belshaw Mark IX Donut Robot® fryers only. Type 'N' accepts the same plunger varieties as Types 'B' and 'F', but with shorter shaft length.

All Donut Robots® employ an automatic cake donut depositing system that only requires filling with batter. The **Donut Robot® Automatic Depositor** operates with its own set of plungers and attachments for forming plain, star, french cake, mini, ball, nugget, dunkerette, and crescent donuts. <sup>1</sup>



Belshaw Type 'B'



Belshaw Type 'F'



Type 'F' Deluxe



Belshaw Type 'N'

### Donut Robot® Automatic Depositors



Left: Donut Robot® Standard depositor



Right: Automatic Type 'N' depositor (for Mark IX only)



# Cake Donut Depositors: Type 'B' • 'F' • 'N' • Donut Robot®

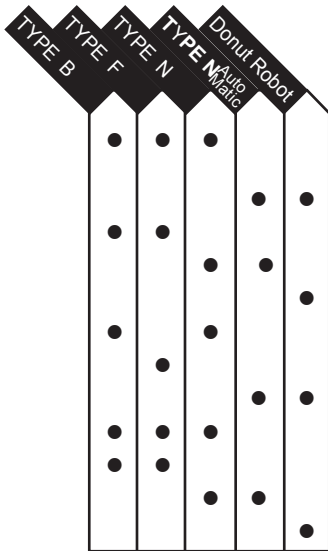

## Product Information

- Aluminum alloy frame and arm assembly, hardened steel cams, bronze trip arms and bushings, aluminum hopper
- Stainless steel and aluminum cutter unit, aluminum hopper
- 15 lb/7 kg capacity hopper
- 12 lb/5 kg capacity hopper
- 10 lb/4.5 kg capacity hopper
- Hand crank operation
- Motorized crank, controlled by hand trigger
- Motorized, synchronized with fryer
- Wall mounting or column mounting available
- Compatible with Type B/F plungers and cylinders only (see Plunger section)<sup>1</sup>
- Compatible with Type N plungers and cylinders only (see Plunger section)<sup>2</sup>
- Compatible with Donut Robot® plungers, no separate cylinder required<sup>3</sup>

## Notes

- Type B and F plungers and cylinder are ordered separately from depositor (see plungers section of product guide)
- Type N comes with plain plunger and cylinder as standard.
- Plain 1 9/16" plunger supplied standard with Donut Robot Mark 1 to Mark 6. See Cake Donut Plungers section for details of Donut Robot plungers and attachments

### Type B Depositor

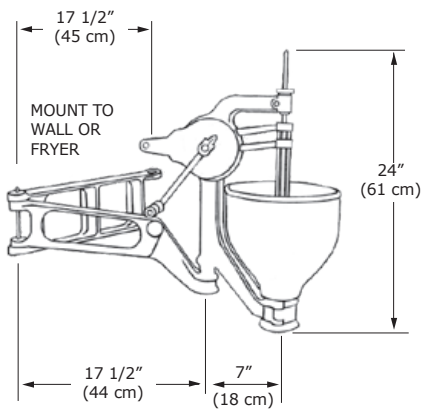

### Type F Depositor

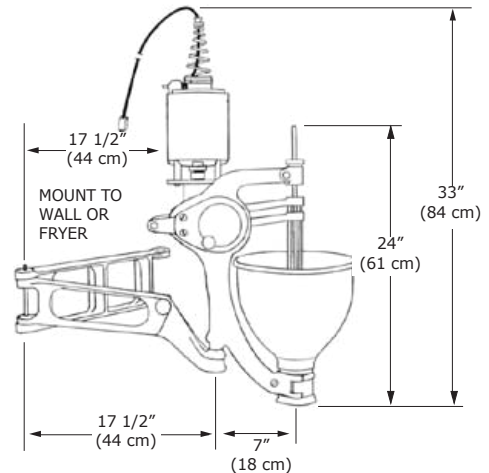

### Type N Depositor (Standard)



USE WITH 616 FRYER (CUT-N-FRY) OR SIMILAR

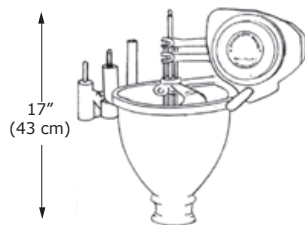

### Type N Depositor (Automatic)

USE ONLY WITH DONUT ROBOT MARK IX

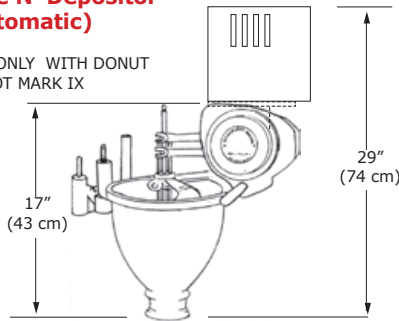

### Donut Robot® Depositor

USE ONLY WITH DONUT ROBOT FRYERS

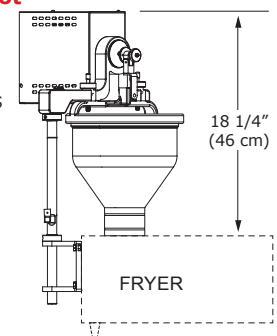

## Dimensions And Power

MODEL	APPROX. SHIPPING WEIGHT		HOPPER CAPACITY		MAX OUTPUT	ELECTRICAL					
	Depositor only	Depositor+mount	lbs.	kg.		120V,60Hz,1ph		120V,50Hz,1ph		240V,50/60Hz,1ph	
					W	A	W	A	W	A	
Type B	30 lbs (14 kg)	48 lbs (22 kg)	15	7	100	Mechanical operation only					
Type F	50 lbs (23 kg)	67 lbs (31kg)	15	7	115	570W	4.9	495W	4.5	510W	2.3
Type N	25 lbs (11 kg)	32 lbs (15 kg)	12	5	100	Mechanical operation only					
Type N Automatic	N/A	45 lbs (21 kg)	12	5	n/a	480W	4.1	480W	4.1	480W	2.1
Donut Robot Mark I-VI	N/A	36 lbs (16 kg)	10	4.5	n/a	250W	2.2	240W	2.1	240W	1.1