



The worldwide leader in donut production equipment

+1.206.322.5474 • info@belshaw.com • www.belshaw.com

TABLETOP FRYERS

616B Fryer Cut-N-Fry Hushpuppy Maker Cut-N-Fry Loukoumathes Tempura Fryer

616B Fryer

The 616B fryer includes 16" x 16" fryer with cover/drain tray and 2 frying screens. It occupies under 3 square feet (1 sq. m) of counter space and weighs only 44lbs. (20kg). With a capacity of up to 35 dozen average size donuts per hour, it represents the best possible use of space for its size. It is designed for use with Belshaw's Type K donut depositor or as part of a Cut-N-Fry system (below). The 616 can also fry raised donuts.

The 16" x 16" kettle area has room for 16 medium size donuts at a time. The fryer is constructed with durable, sanitary materials. The heavy duty element tilts out of the way to facilitate cleaning. A drain tray and 2 screens with handles are standard.

616 'Cut-N-Fry'

This versatile combination enables bakeries and others to fry cake and raised donuts in less than 3 feet (1m) of counter space up to 35 dozen donuts per hour, ideal for fast production during slack periods. The Cut-N-Fry is based on the 616B fryer and includes Belshaw's full-featured Type 'N' Donut Depositor, it can make multiple varieties of cake donuts with Belshaw plungers and attachments.

Hushpuppy Maker

A specialized version of the 'Cut-N-Fry', the Hushpuppy Maker is identical except for the specialized Hushpuppy plunger used in the Type N depositor. The Hushpuppy Maker plunger deposits three Southern Hushpuppies per plunger stroke.

Cut-N-Fry for Loukoumathes

A specialized version of the standard 'Cut-N-Fry', the Cut-N-Fry for Loukoumathes is identical except for the specialized Loukoumathes plunger used in the Type N depositor. The Loukoumathes plunger deposits three Loukoumathes per plunger stroke.

Tempura Fryer

Tempura makers find the Belshaw 616B's small size, shallow depth and overall simplicity ideal for tempura frying.

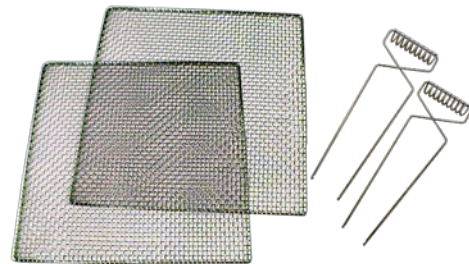
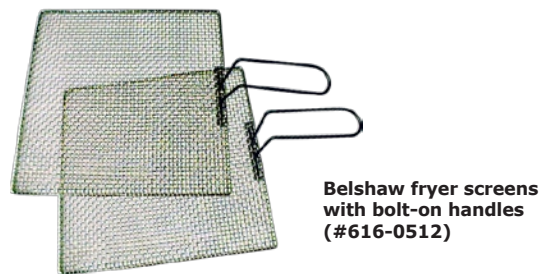
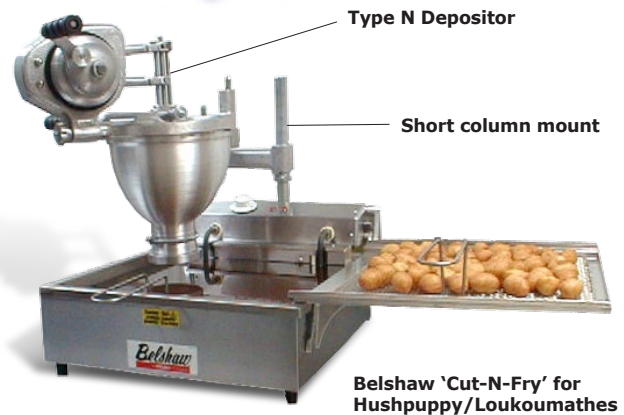
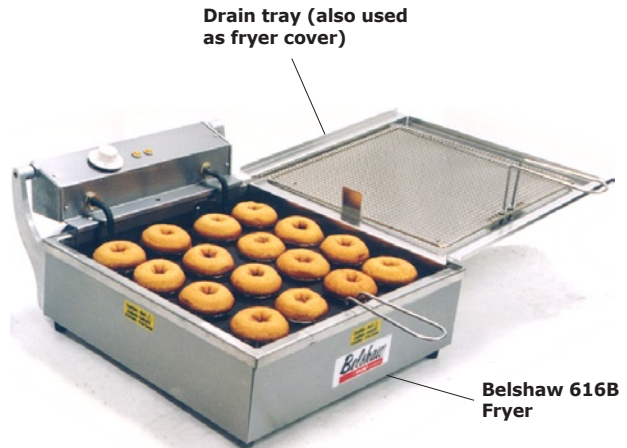

Features

616 Fryer

- 16" x 16" fryer with SST element.
- Choose either 208V or 236V model. All models can accommodate 50 or 60 Hz
- 6 ft (1.83m) power cord.
- Drain tray doubles as fryer cover. Can be attached right or left as desired.
- 2 frying screens with handles, 15" x 15" (38cm x 38cm), nickel-plated steel.
- Removable kettle for easy cleaning
- Tilt-up element for easy rinse-out of fryer kettle
- 2 pilot lights: Power 'ON' and Thermostat 'ON'
- High temperature limit switch.
- Stainless steel kettle and body. Stainless steel and aluminum control panel.
- Optional submerger screen with 1½" spacers to submerge round products such as loukoumathes, hushpuppies and doughnut balls. (#HP-1004)

616 'Cut-N-Fry'

- 616 Fryer as above.
- Type 'N' Cake Donut Depositor with column mount.
- Short column mounting kit (#N-1033)
- 1-3/4" plain cake donut plunger, (#N-1007SS x1-3/4)
- Type N Cylinder, (#N-1035L-A)
- Plunger and cylinder can be selected from the full range of Type N plungers. Plunger and cylinder sizes must match. The most common are:
 - 1-3/4" plain cake donut plunger, (#N-1007SS x1-3/4)
 - Type N Cylinder, (#N-1035L-A)

Certifications



616 Hushpuppy Maker

- 616 Fryer as above.
- Type 'N' Cake Donut Depositor with column mount.
- Short column mounting kit (#N-1033)
- 2" Hushpuppy plunger, forms 3 hushpuppies per plunger stroke, #N-1009BSS-103DB
- Type N Cylinder, (#N-1035L-B)

616 Cut-N-Fry for Loukoumathes

- 616 Fryer as above.
- Type 'N' Cake Donut Depositor with column mount.
- 2" Loukoumathes plunger, forms 3 loukoumathes per plunger stroke, #N-1009BSS-103C
- Type N Cylinder, (#N-1035L-B)

Screens

- For all except raised donuts, use screens provided.
- For raised donuts, additional screens may be needed to hold donuts while proofing. Select either:
 - Screens with bolt on handles (if proofer will hold them). These are 21" (53cm) total length
 - Up to 20 screens without handles (also known as "Proofing Screens", #616-0007), with 2 detachable screen handles (#616-0007A) for lifting screens from fryer (see photo on front side)

Submerger Screen / Detachable Handles

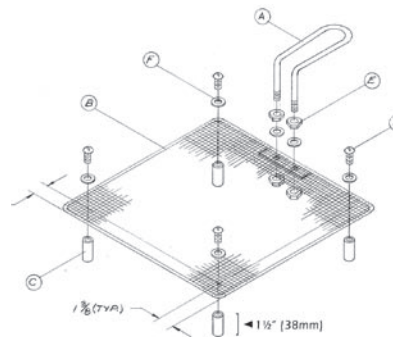

Left: Submerger screen with 1¼" spacers (HP-1004)

Dimensions And Power

MODEL	DIMENSIONS				Shortening Capacity	ELECTRICAL DATA				APPROX. SHIPPING WEIGHT
	Width closed	Width open	Depth	Height		208V/60/1		240V/60/1		
						KW	A	KW	A	
616 Fryer only	18" (46cm)	36" (91cm)	22" (56cm)	10" (61cm)	55 lbs (25kg)	4 KW	19.2 A	4.4 KW	18.6 A	55 lbs / 25kg
616 CUT-N-FRY	18" (46cm)	36" (91cm)	22" (56cm)	24" (61cm)	55 lbs (25kg)					90 lbs / 41kg
616 Hushpuppy Maker	18" (46cm)	36" (91cm)	22" (56cm)	24" (61cm)	55 lbs (25kg)					90 lbs / 41kg
616 CUT-N-FRY Loukoumathes	18" (46cm)	36" (91cm)	22" (56cm)	24" (61cm)	55 lbs (25kg)					90 lbs / 41kg
SERVICE REQUIRED:	30 Amp, 208 OR 240 Volts, with NEMA 6-30R; 2 pole, 3 wire grounding									