



The worldwide leader in donut production equipment

+1.206.322.5474 • info@belshaw.com • www.belshaw.com

## GAS FRYERS (Floor Model)

### Models: 718LCG, 724CG, 734CG

Belshaw's 700 series gas-heated Open Kettle Fryers are designed to efficiently produce high quality donuts. Our tube-burner design offers superior performance over flat-bottom fryers by providing a cold zone under the fryer tubes. This cold zone collects deposits and ensures longer shortening life and higher quality donuts.

Belshaw has leveraged its specialization in donut production to add design features that add value for our customers. Our 'Controlled Combustion' burner tube technology leads the industry in gas efficiency, generating savings throughout the life of the fryer.

Belshaw's 700 series Open Kettle Fryers accommodate the EZ Melt under-kettle shortening melter/filter as well as Belshaw Type 'B' and Type 'F' donut depositors. Easy-to-use submerger screens can be added to further improve production efficiency.

Belshaw provides a full line of complementary equipment that saves labor cost and improves quality consistency:

- EP18-24 Proofing Cabinet
- Type 'B' and Type F cake donut depositors
- EZ Melt Shortening Melter-Filter
- SF Shortening Filter
- HI24 Production Icers
- H&I 2-4 Icing Tables
- HG, HGEZ Hand Glazers

### Products made commercially using floor model gas fryers:

- Donuts
- Hushpuppies
- Funnel cakes
- Elephant ears
- Fried pies
- Loukoumathes
- Falafel
- Paczkis, porogis
- Beignets
- Fritters, fried dough
- Crab cakes, clam strips
- Fried corn
- Fried vegetables
- + More fried goods of all kinds



**Belshaw 724CG Gas Fryer  
(with Type 'F' donut depositor,  
EZ Melt filter and submerger)**



718LCG gas fryer (18" x 26")



724CG gas fryer (24" x 24")



734CG gas fryer (34" x 24")



Frying screen (identical to proofing screen, but has bolt-on handles). Screens are reinforced wire mesh, spaced 1/4" (6mm) apart, manufactured from nickel-plated steel.



Screen cradle and proofing screen. The best way to transfer raised donuts from proofer to fryer.



Detachable handles and proofing screen. For cake or raised donuts.

**BELSHAW BROTHERS, INC** • 814 44th St NW, Suite 103, Auburn, WA 98001 • USA

Tel +1.206.322.5474 • Fax +1.206.322.5425 • Email info@belshaw.com • www.belshaw.com

©2009 Belshaw Adamatic Bakery Group • Product specifications may be changed without notice.





**Standard Features**

- Electronic ignition on all models
- Fryers are equipped for natural gas. A conversion kit is available for changeover to Liquid Propane.
- Stainless steel tank, cabinet, and drain tray (specify whether drain tray should be on left or right side when ordering).
- 2 nickel plated cake donut frying screens with bolt-on heat dissipating handles.
- Adjustable legs boltable to floor.
- Drain valve control accessible on exterior of fryer.

**Options**

- Draft inducer
- Screen cradle (enables screen insertion and removal without handles).
- Submerger
- Liquid propane

**700 Series Fryers Capacity Chart**

(Dozen donuts/hour @ 90-second frying time. Production will vary depending on product size, shortening temperature and composition of donut)

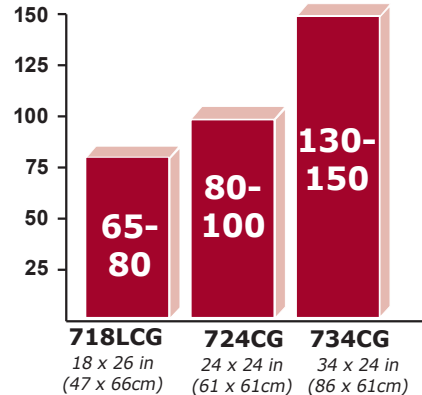

**718LCG/724CG/734CG Gas Fryers**

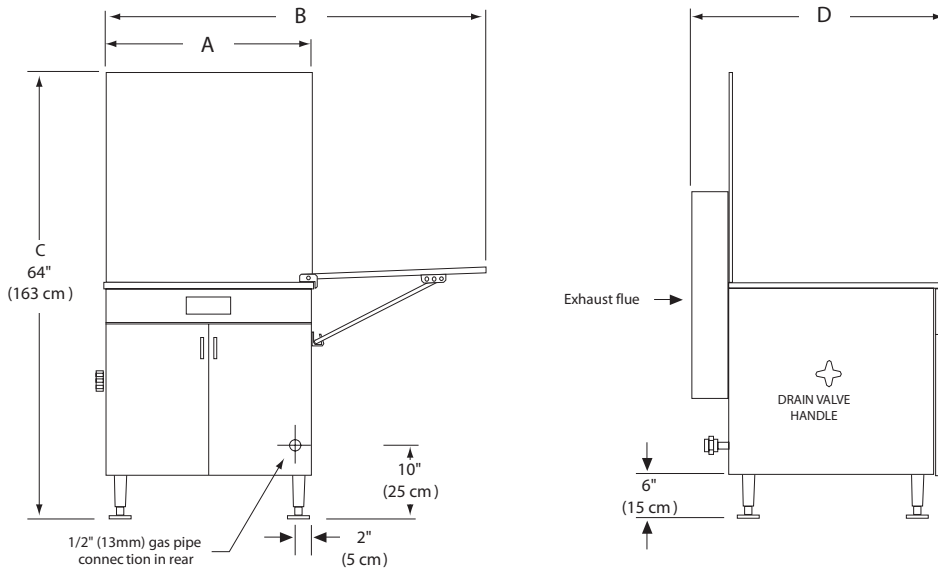

**Dimensions**

MODEL	A	B	C	D	FRYING AREA	SHORTENING CAPACITY	APPROX. SHIPPING WEIGHT
	Width closed	Width open	Height	Depth			
718LCG	25"(64cm)	46"(117cm)	64"(163cm)	39"(99cm)	18" x 26" (46cm x 66cm)	94lbs (43kg)	280 lbs (130 kg)
724CG	30"(76cm)	55"(140cm)	64"(163cm)	37"(94cm)	24" x 24" (61cm x 61cm)	106lbs (48kg)	310 lbs (140 kg)
734CG	40"(102cm)	75"(191cm)	64"(163cm)	37.5"(95cm)	24" x 34" (61cm x 86cm)	195lbs (89kg)	450 lbs (205 kg)

**Gas and Electrical**

MODEL	VOLTAGE (either/or)		GAS PRESSURE	
	BTU/hr	Amps	Nat. Gas	Propane
718LCG	44,000	5 A	7 in W.C. (1742 pa)	11 in W.C. (2740 pa).
724CG	60,000	5 A		
734CG	89,000	5 A		

**Screen Size And Weight**

MODEL	SCREEN SIZE	APPROX. SHIPPING WEIGHT (Box of 12)
718CG	17" x 25" (43 x 63 cm)	45 lbs (21 kg)
724CG	23" x 23" (58 x 58 cm)	55 lbs (25 kg)
734CG	23" x 33" (43 x 63 cm)	75 lbs (34 kg)

